

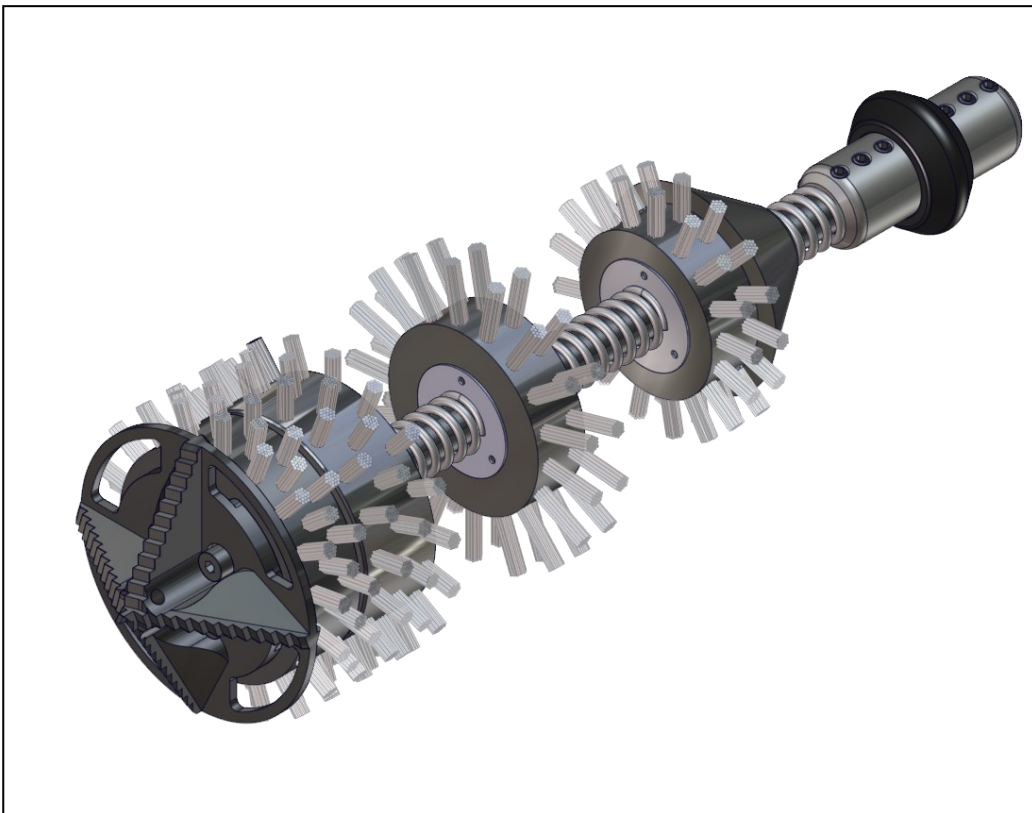

Operating & Safety Manual

Twister+ DN150, DN 200 & DN225 / 6", 8" & 9" for 18mm/¾" Shaft



WARNING

These instructions are for your personal safety. Always ensure that you have read and understood these instructions before using any tools of the Twister+ range. Please also read and understand the Maxi Miller Power+ manual before using the Twister+ tool.



We now have resellers in the U.S., Europe & Australasia.

Locate your reseller at picotesolutions.com

TABLE OF CONTENTS

TOPIC	PAGE/S
SAFETY INFORMATION & SYMBOLS	3
AVAILABLE SIZES & POWER SOURCES	5
BILL OF MATERIALS	6
ASSEMBLY & USE	11
PRACTICAL TIPS & SAFETY ADVICE	18
MAINTENANCE & SPARE PARTS	20
WARRANTY POLICY & PROCEDURE	23

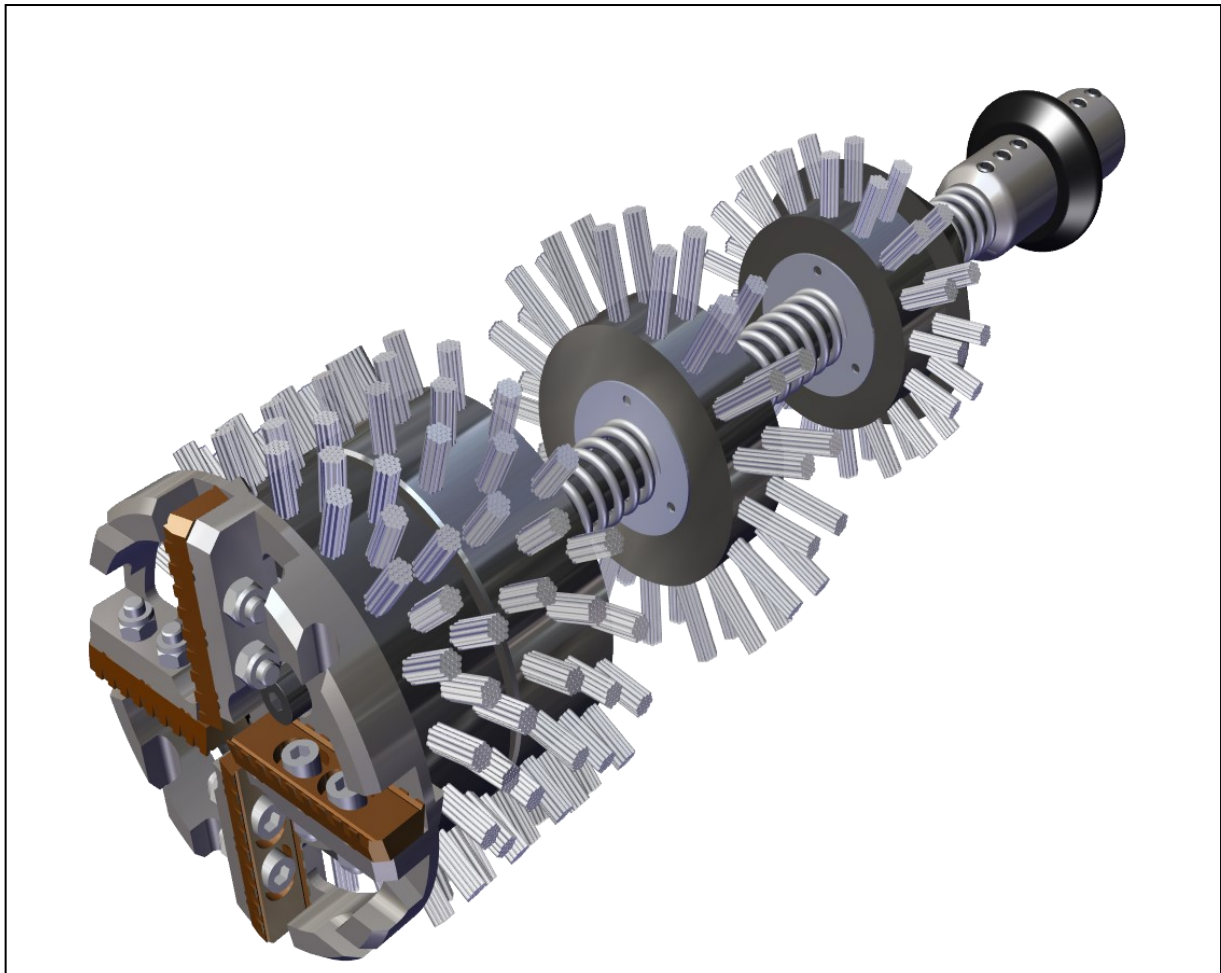

To watch practical demonstration videos, or to download an electronic copy of these Instructions, please visit www.picotesolutions.com. Please note that videos are not intended as a replacement or alternative to this operating and safety manual, but only as an additional learning tool.

SAFETY INFORMATION

WARNING

This section contains important safety information. Failure to comply could result in serious injury or death.

Safety Symbols

Safety symbols are used throughout this manual to draw attention to potential hazards.



Danger
400 Volts

Danger risk of serious injury or death by electrocution, follow instructions



Danger
Electric shock risk

Danger risk of serious injury or death by electrocution, follow instructions



Danger risk of serious injury, follow instructions



Danger risk of serious injury from rotating parts



Danger risk of serious injury from hot parts



Danger do not touch. Risk of injury, follow instructions

Personal Protective Equipment (PPE)

Always use Personal Protective Equipment when using the Twister+ and Miller systems, including suitable overalls / protective clothing & footwear and the following:



Always wear suitable eye protection when using the Twister+ to prevent sewage, chemicals or other dust from irritating your eyes.



Always wear suitable ear protection when using the Twister+ and Miller systems to prevent any hearing loss.



Always wear suitable cut-resistant gloves when using the Twister+ to prevent any hand injuries. Any open injuries or skin irritations should be covered at all times to avoid contact with sewage, chemicals or dust.



Always wear a suitable ventilation mask when using the Twister+ or Miller systems to prevent any resin dust or fumes being inhaled or consumed, which can cause occupational asthma or dermatitis as well as eye irritation.

Safety Symbols cont.

Safety symbols are used throughout this manual to draw attention to potential hazards.

Always remember



Dust produced can be dangerous to your health, inflammable or explosive.

Make sure the drain pipe has been **opened** and **ventilated** to stop any gases forming in the lateral drain where the work takes place.

Before assembly, use, replacement of parts or maintenance, unplug the Picote milling machine or your hand drill from its power socket.



Danger
400 Volts

High voltage. Failure to comply may lead to serious injury including electric shock or injury from rotating parts!

ELECTRICAL SET UP REQUIREMENTS FOR MAXI MILLER POWER PLUS

⚠ WARNING READ THE MAXI MILLER POWER+ MANUAL BEFORE USE



Danger
400 Volts

Electrical shock can cause serious or fatal injury. Only qualified personnel should install, maintain or troubleshoot this equipment.

Picote recommends that a properly trained electrician be available to wire a power distribution box to whatever power source is available. In the case where a generator is required, a minimum power requirement of 25,000 KW/KVA 3 Phase 480 volt is necessary.

The Power Plus is a dual voltage 3 phase power configuration. It uses a 10 gauge 4 wire cord.

Be sure the system is properly grounded/earthed before applying power. Do not apply power before you ensure that grounds are connected. Electrical shock can cause serious or fatal injury. Follow the National Electrical Code (NEC) and local codes for the safe installation of the equipment.

Do not operate the Power Plus Miller until you are sure that you are completely familiar with the safe operation of the machine, all accessories and safety equipment. Improper use can lead to severe injury. The user manual defines proper use of this equipment.

Contact Picote if you do not understand any procedure or operation concerning this equipment or the user manual.

SAVE ALL WARNINGS AND INSTRUCTIONS FOR FUTURE REFERENCE

⚠ WARNING *This section contains important safety information. Failure to comply could result in serious injury or death.*

ENVIRONMENTAL

Operational Ambient Temperature Range: -10...50 °C (14...122 °F) frost and condensation free

Storage Ambient Temperature Range: -20...60 °C (-4...140 °F) frost and condensation free

TRANSPORT

Picote tools should be transported in car or other vehicle properly secured to prevent any sudden movements caused by hard braking or accident. Using lidded boxes which are fastened and stored on the bottom of a van is recommended.

Never transport machine with tool attached to the shaft.

If using pick-up or trailer to transport Picote machine or tools, cover the products to protect them from raining water and dust.

STORAGE

It is recommended that tools are stored indoors protected from rain and sunlight and in constant ambient temperature.

Clean used Twister+ with fresh water after taken out from the pipe. Store in place where tool can dry out properly.

Constant water exposure and attached dirt expose tool to rust.

DISPOSAL

Twister+ components can be separated. Recycle metallic components in metal waste collection points and plastic components in plastic waste collection points.

Always follow the local waste handling rules and regulation.

AVAILABLE SIZES & POWER SOURCES

The Twister+ products have a variety of different application purposes. When a correct tool head is adapted the main purpose of the Twister+ is to be used for reinstatements. With the Crusher head, the Twister+ can be used to remove collapsed linings, concrete, limestone or nails & other metal inserts. The actual Smart Crusher tool with a different body is recommended for tough removal work.

Selecting the correct Twister+ for the job

Choose your Twister+ according to the size of the original host pipe.

Place the tool completely inside the drain before powering up the tool.

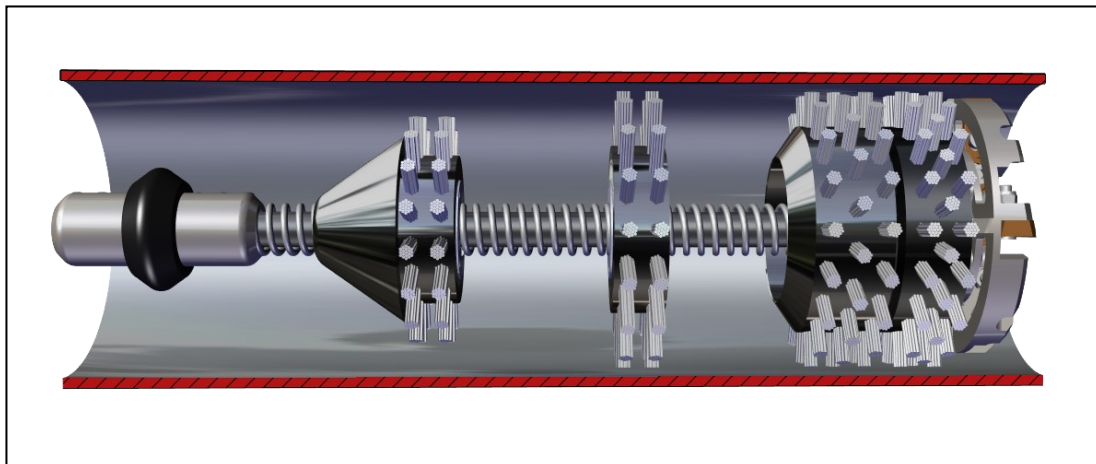

! WARNING



TWISTER	Shaft size mm/inches	BEND 90°	BEND 45°
Twister DN150 / 6"	18 / ¾"	YES	YES
Twister DN200 / 8"	18 / ¾"	YES	YES
Twister DN225 / 9"	18 / ¾"	YES	YES

CHOOSING YOUR POWER SOURCE

The Twister+, with the 18mm/¾" diameter shaft, has been designed for and can ONLY be operated with the **Picote Maxi Miller Power+** machine.

The machine should only be connected to a **380-480 Volt (3-phase)** power supply. The power source has to be grounded (earthed).

CHOOSING YOUR DRILL HEAD

The Twister+ can be used with the Drill, Concrete Remover or Crusher Heads.

BILL OF MATERIALS DN 150/6"

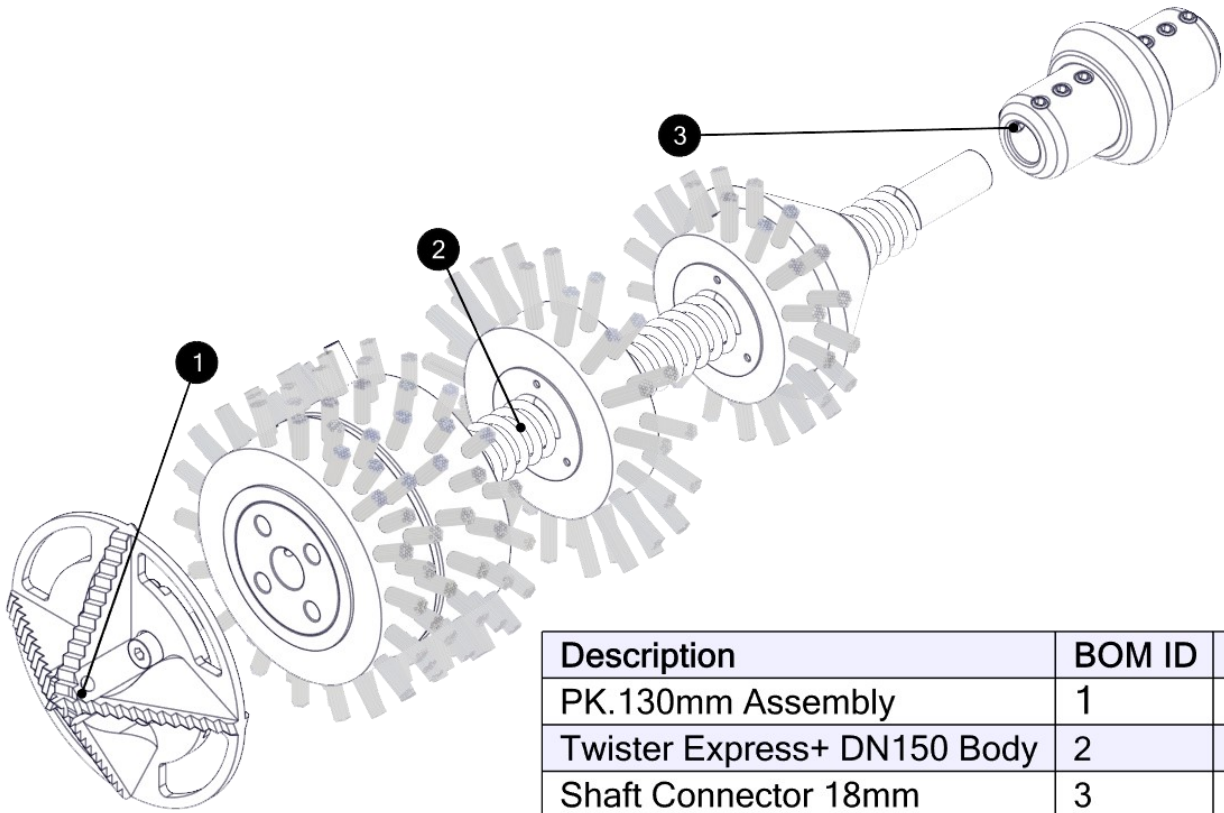

Description	BOM ID	Qty
PK.130mm Assembly	1	1
Twister Express+ DN150 Body	2	1
Shaft Connector 18mm	3	1

BILL OF MATERIALS DN200/8"

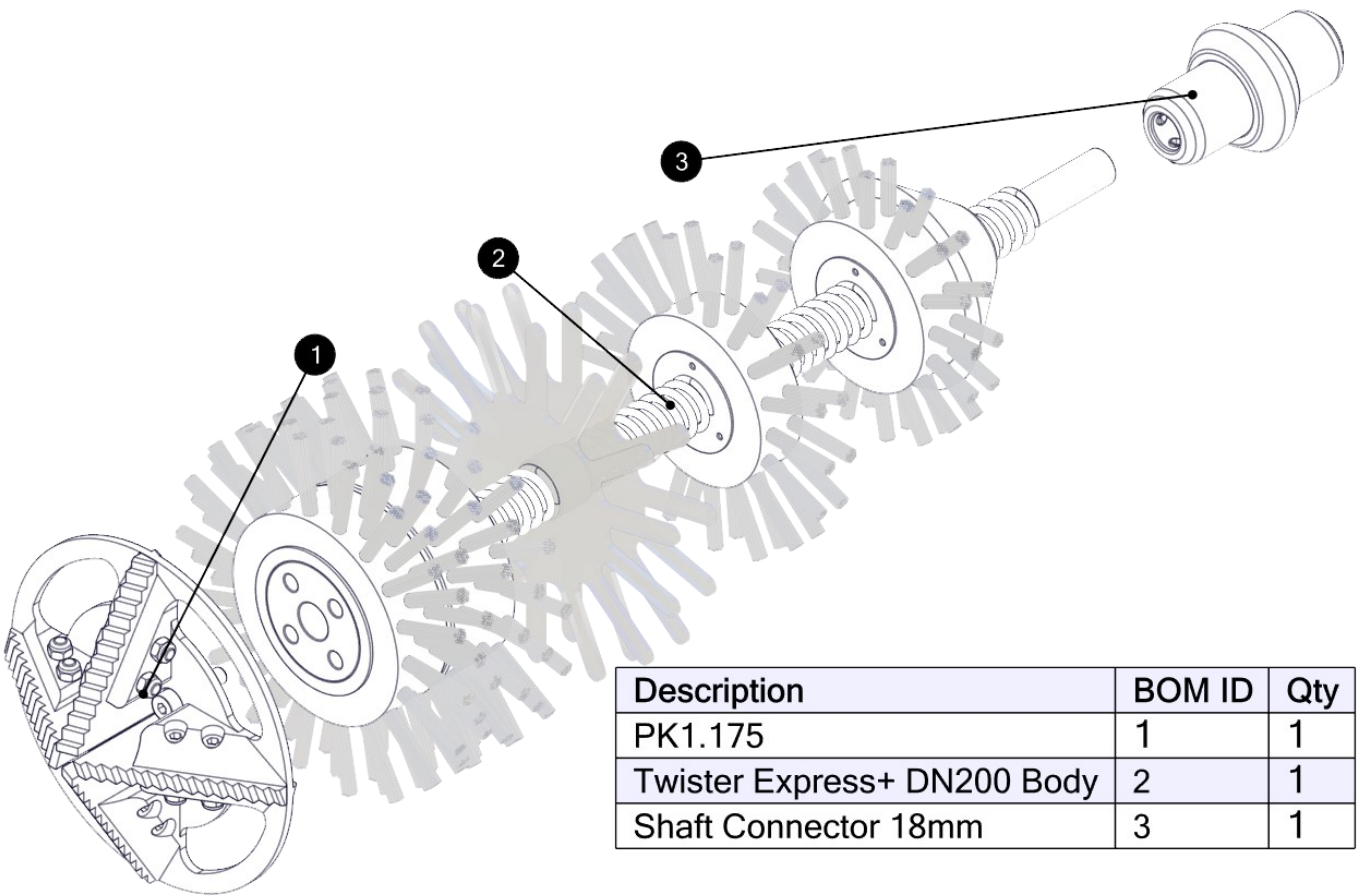

Description	BOM ID	Qty
PK1.175	1	1
Twister Express+ DN200 Body	2	1
Shaft Connector 18mm	3	1

BILL OF MATERIALS DN225/9"

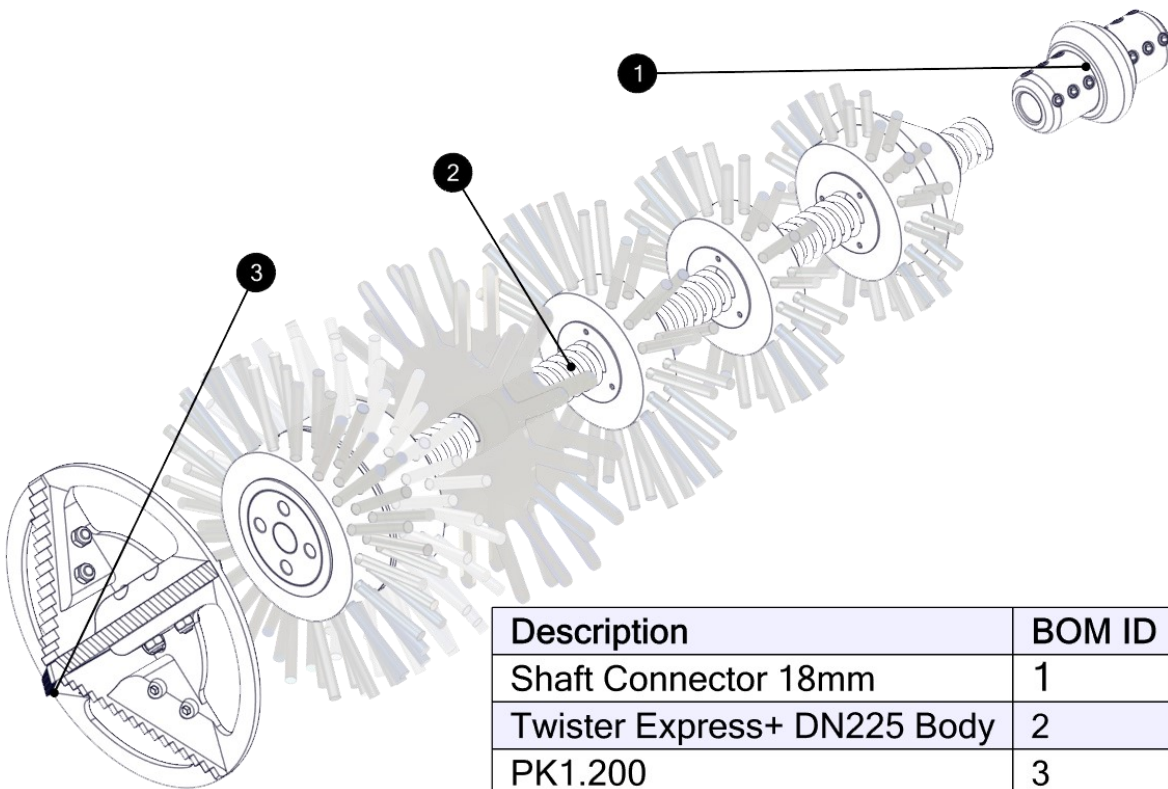

Description	BOM ID	Qty
Shaft Connector 18mm	1	1
Twister Express+ DN225 Body	2	1
PK1.200	3	1

BILL OF MATERIALS - Smart Crusher Head

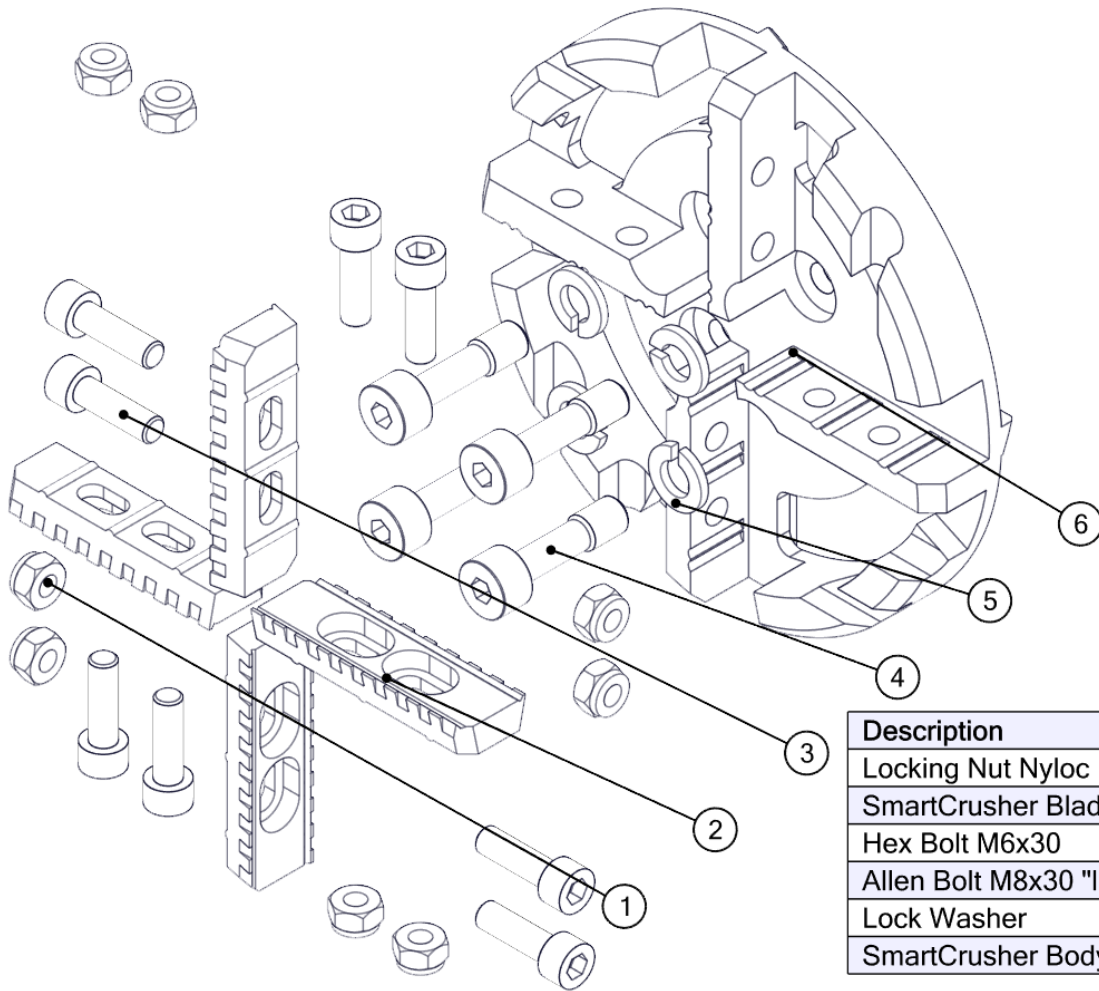

Description	BOM ID	Qty
Locking Nut Nyloc M6	1	8
SmartCrusher Blade 150	2	4
Hex Bolt M6x30	3	8
Allen Bolt M8x30 "light"	4	4
Lock Washer	5	4
SmartCrusher Body 150	6	1

BILL OF MATERIALS - Drill head DN200

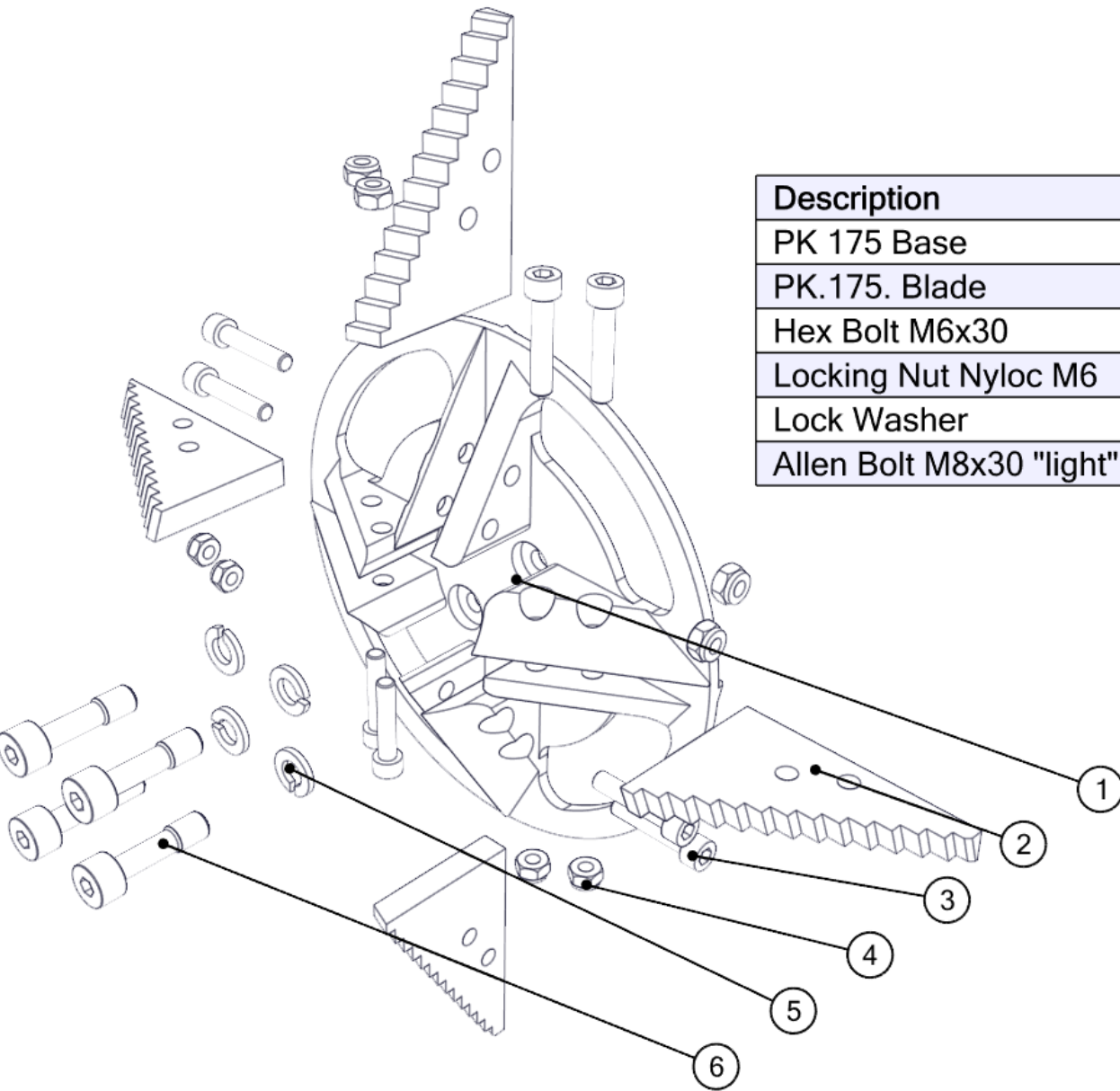

Description	BOM ID	Qty
PK 175 Base	1	1
PK.175. Blade	2	4
Hex Bolt M6x30	3	8
Locking Nut Nyloc M6	4	8
Lock Washer	5	4
Allen Bolt M8x30 "light"	6	4

DN 150/6", DN 200/8" & DN225/9" TWISTER+ ASSEMBLY & USE

First, make sure you have all the required parts. Please see photo parts' lists on page 5-8.



Please read safety information on page 3 before assembly and use.

Twister DN150/6"

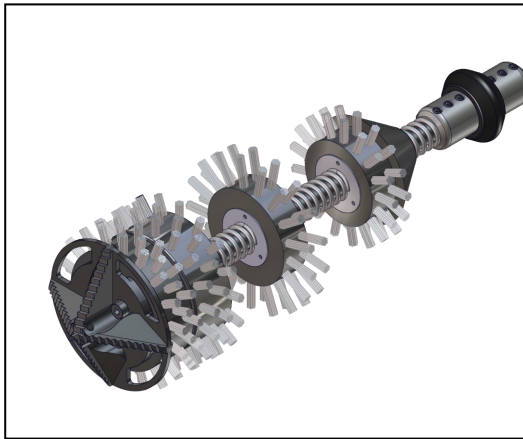

Twister DN200/8"

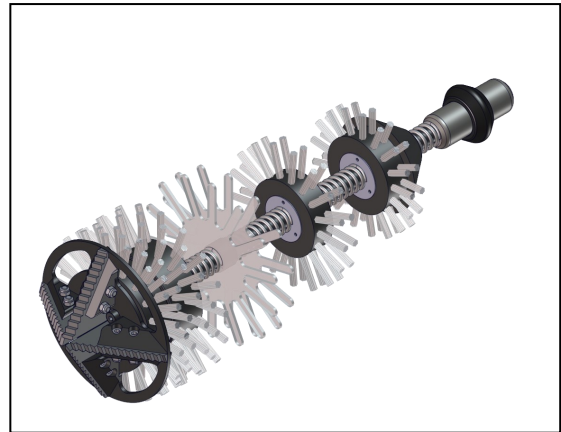

Twister DN225/9"

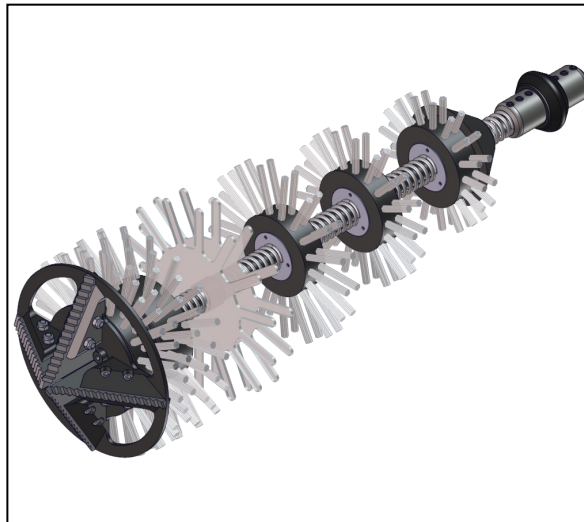

1230130150	Twister+ DN150/6" for 18mm/¾" Shaft
1230130200	Twister+ DN200/8" for 18mm/¾" Shaft
1230130225	Twister+ DN225/9" for 18mm/¾" Shaft

Assembly Instructions—the Smart Crusher Heads

Step 1. Insert the lock washers and hex bolts into their slots. Recommended: Loctite 542 Thread Sealant

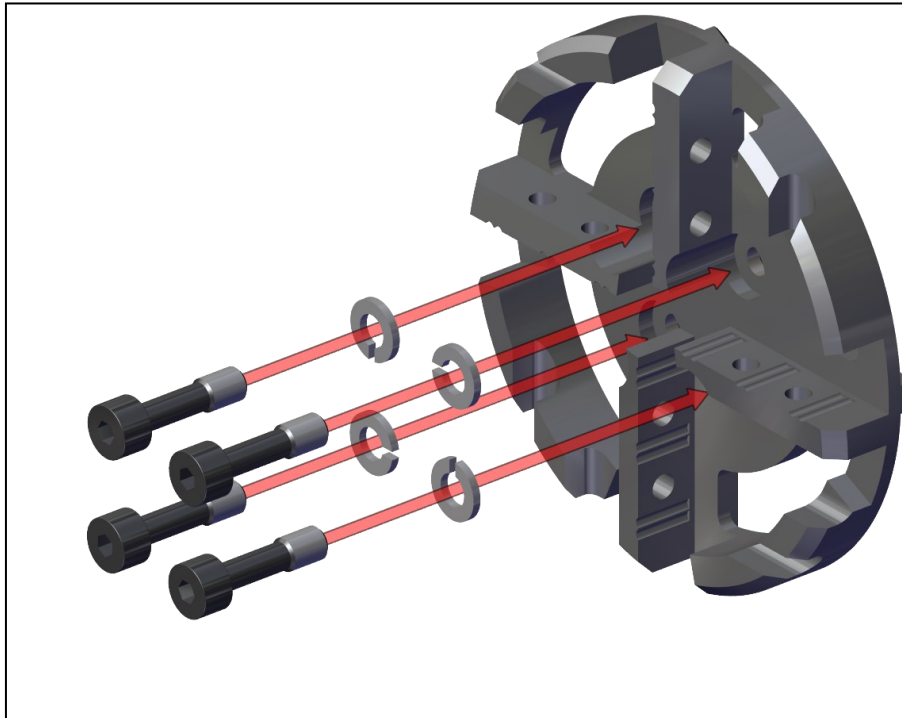
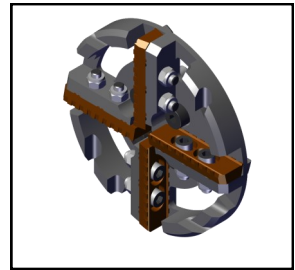

Step 2. Place the Smart Crusher blades into their slots. Pay close attention to alignment as seen on the next page.

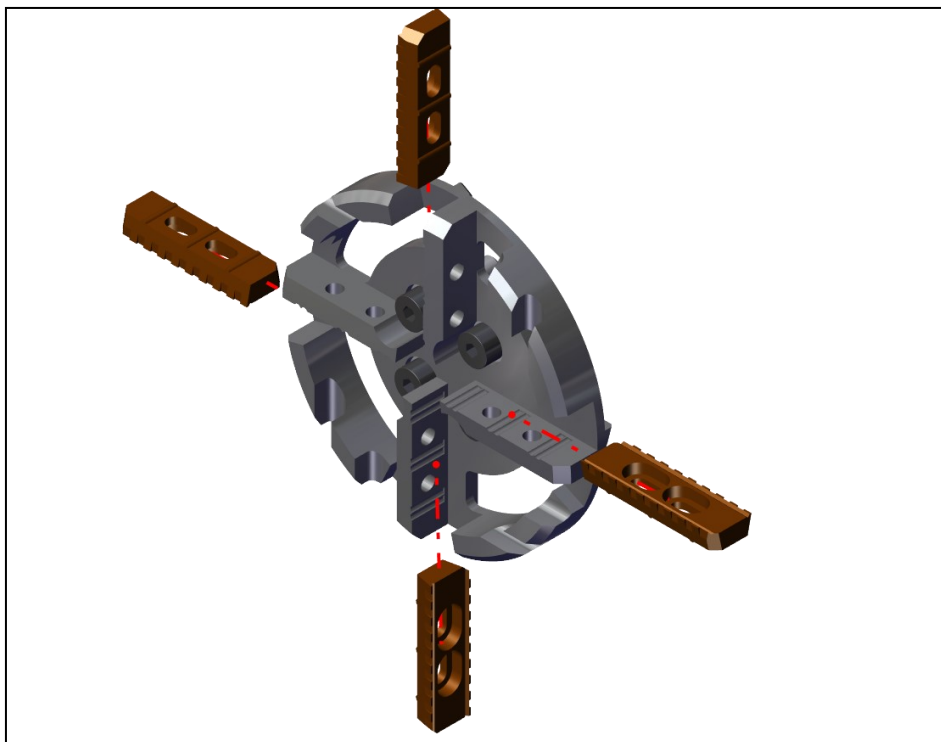

Smart Crusher Heads

Step 3. Place every second blade in alternative slots of the body.

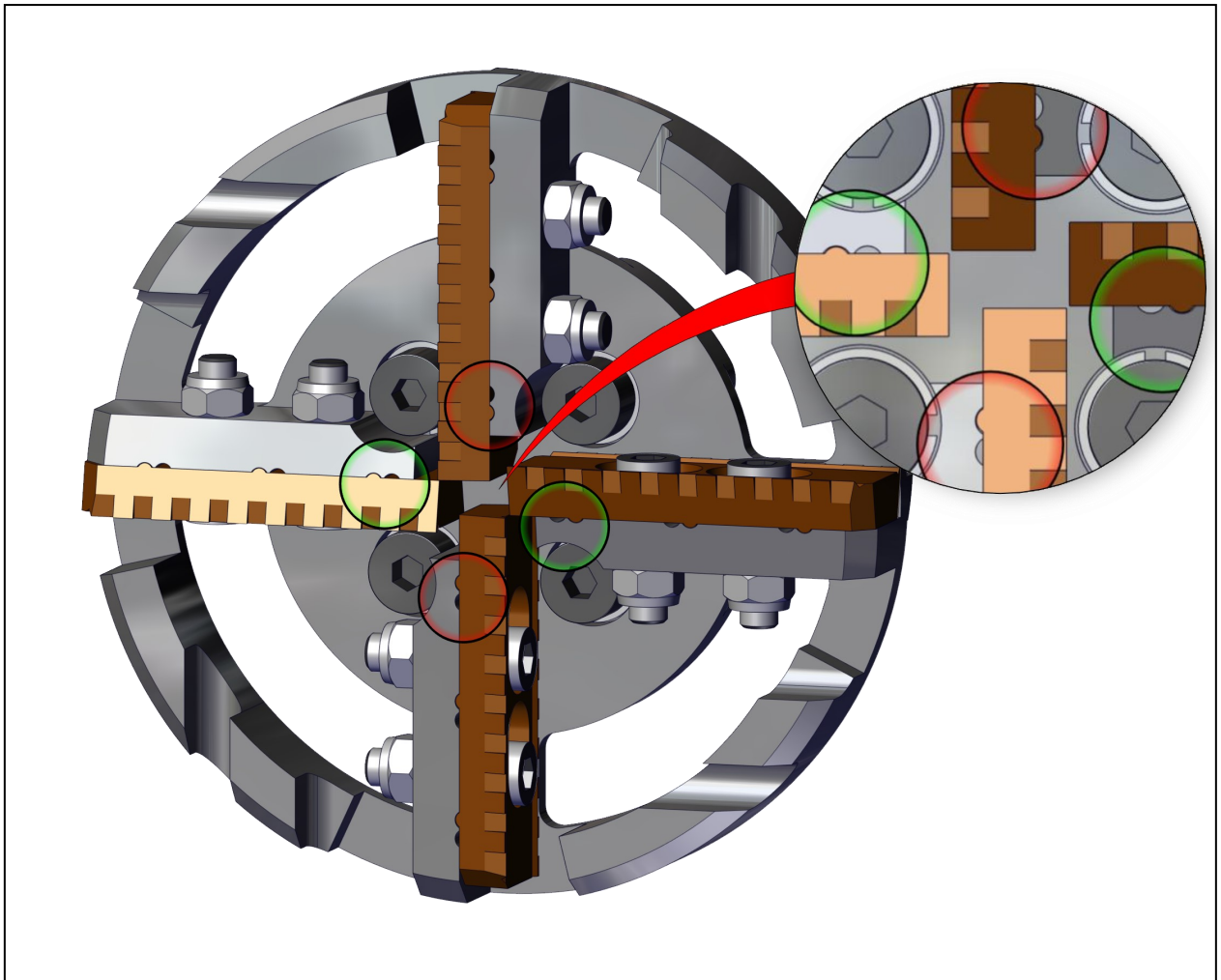
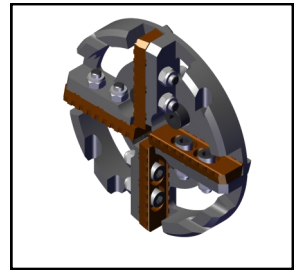

The Smart Crusher can only operate at maximum diameter when the blades are inserted correctly. The two opposite blades need to be closer to the centre. **If the blades are placed incorrectly the head may not be able to progress through the pipe.**

Smart Crusher Heads

Step 4. Insert the mounting bolts and nuts. Tighten bolts.
Locking nuts must be used! Recommended: Loctite 542

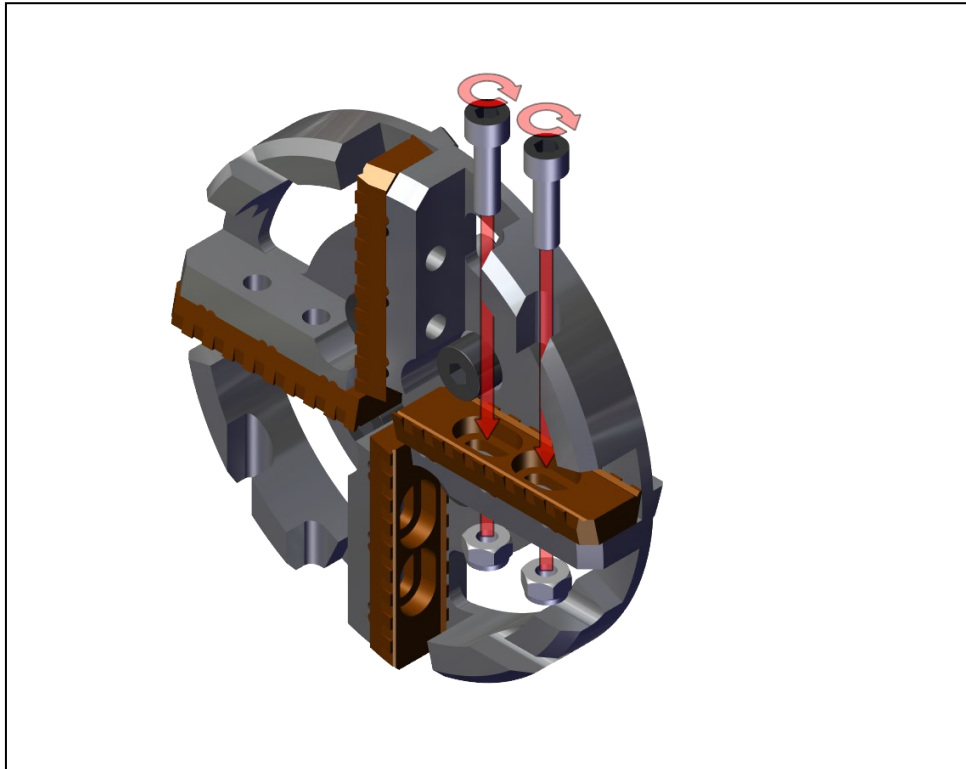
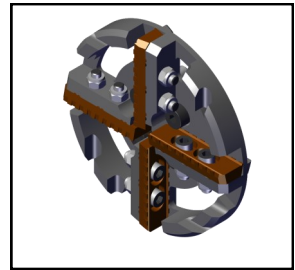

Step 5. Place the rest of bolts and locking nuts into their place as per step 4.

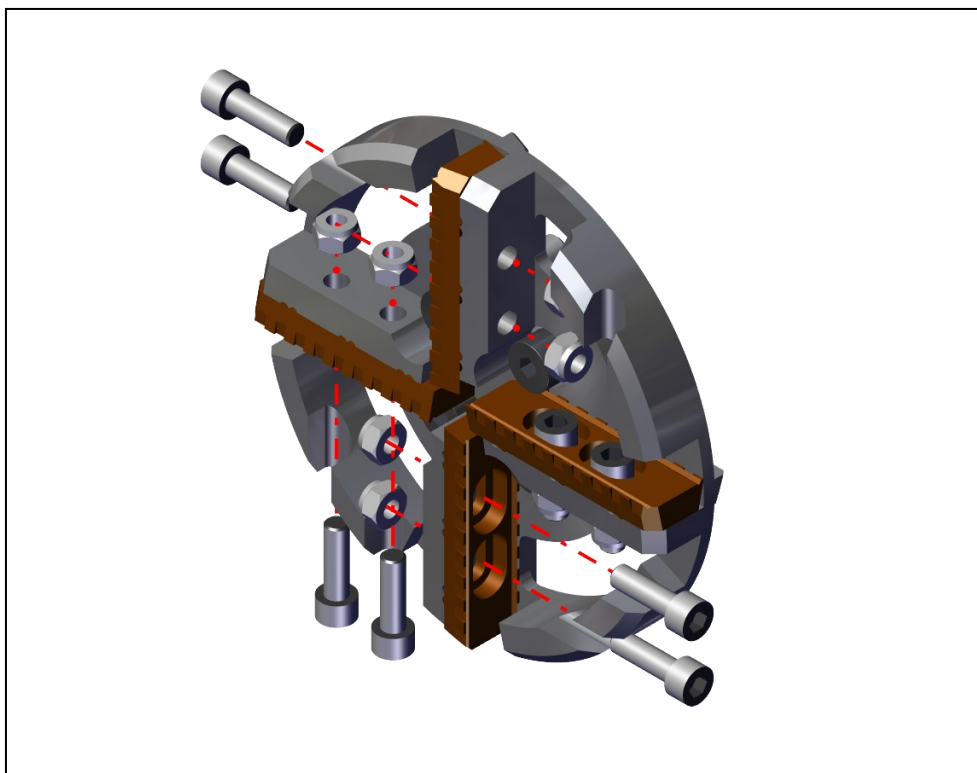

Drill Heads DN200 & DN225/8" & 9"

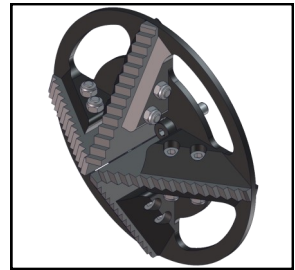

Step 1. Insert the blades into their slots.

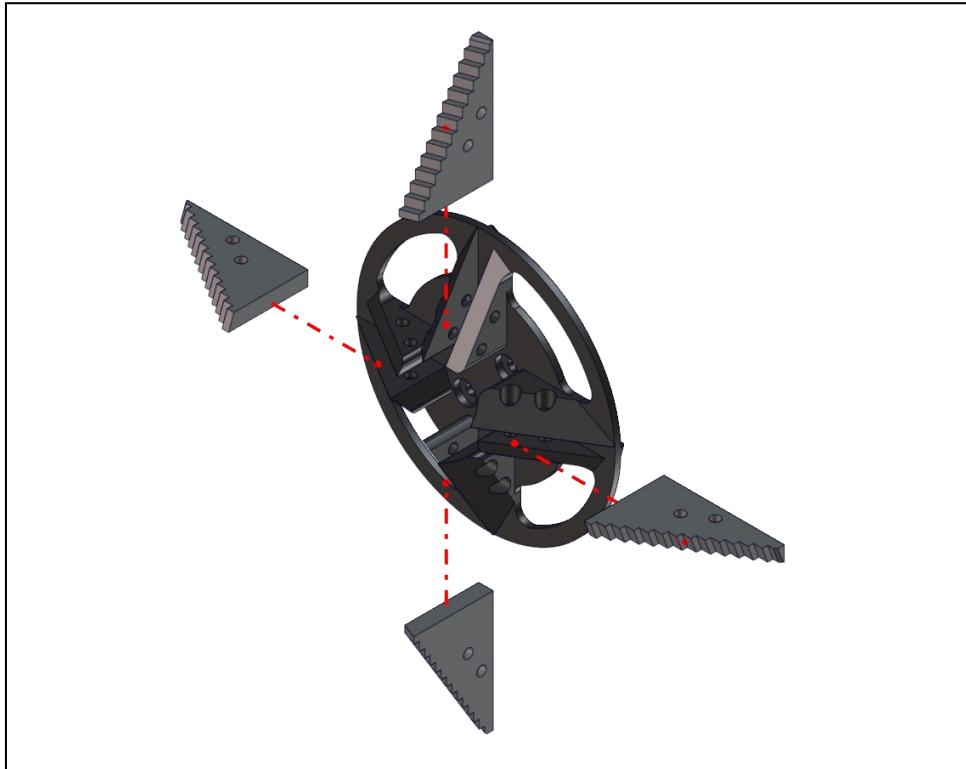

Step 2. Place the bolts and nuts in position and tighten them. **Locking nuts must be used! Recommended: use Loctite 542 Thread Sealant.**

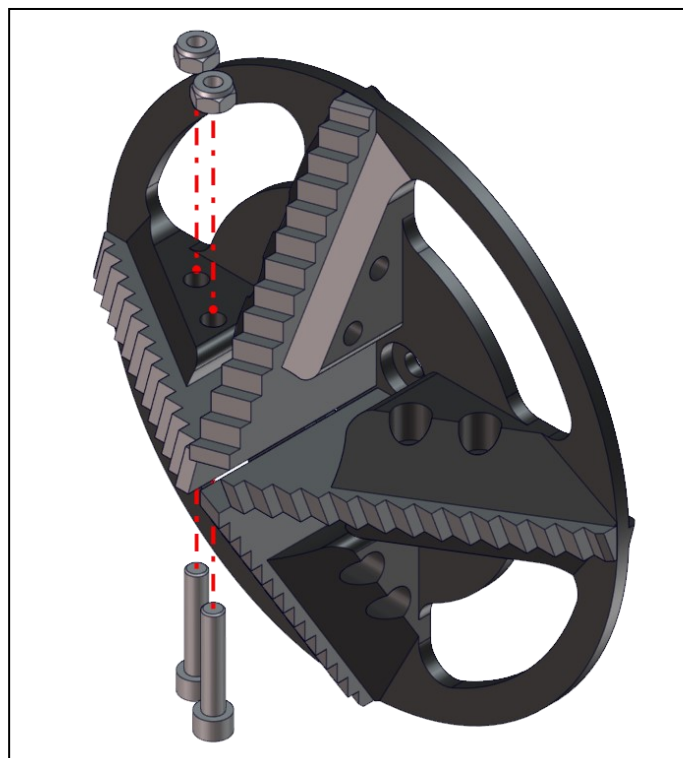

Drill heads DN200 & DN225/8" & 9"

Step 3. Insert the other bolts and nuts into their slots.

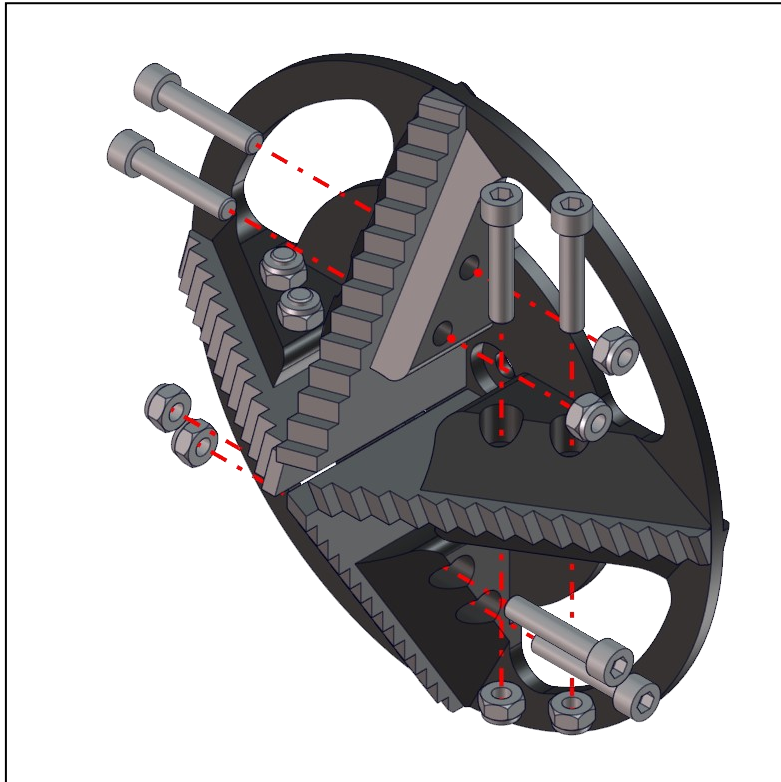
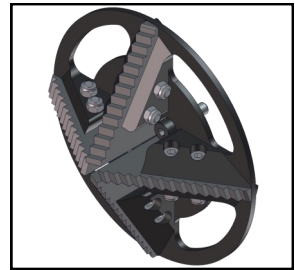

Step 4. Place the Allen Bolts (M8) and locking washers into their slots.

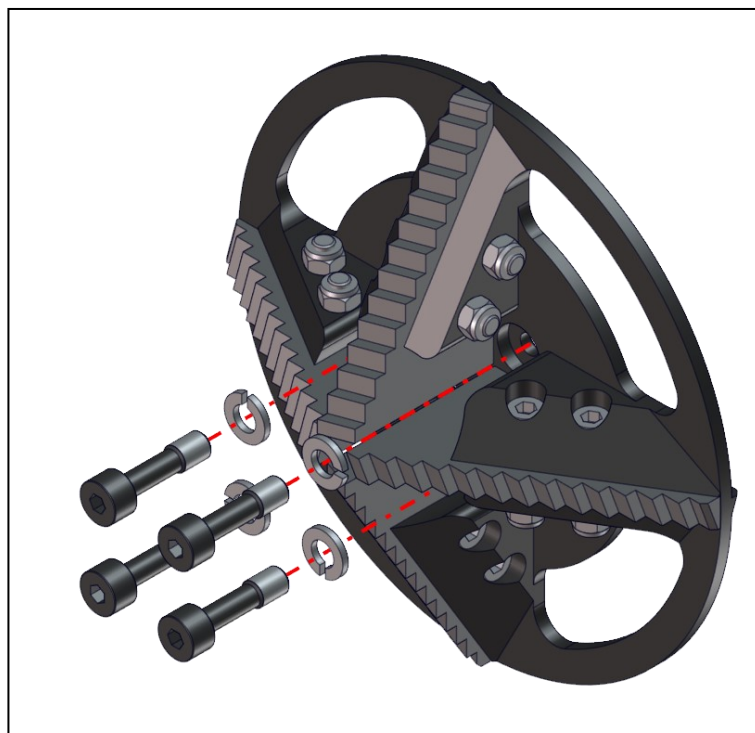

Attaching the Drill Head to the Twister+ body.

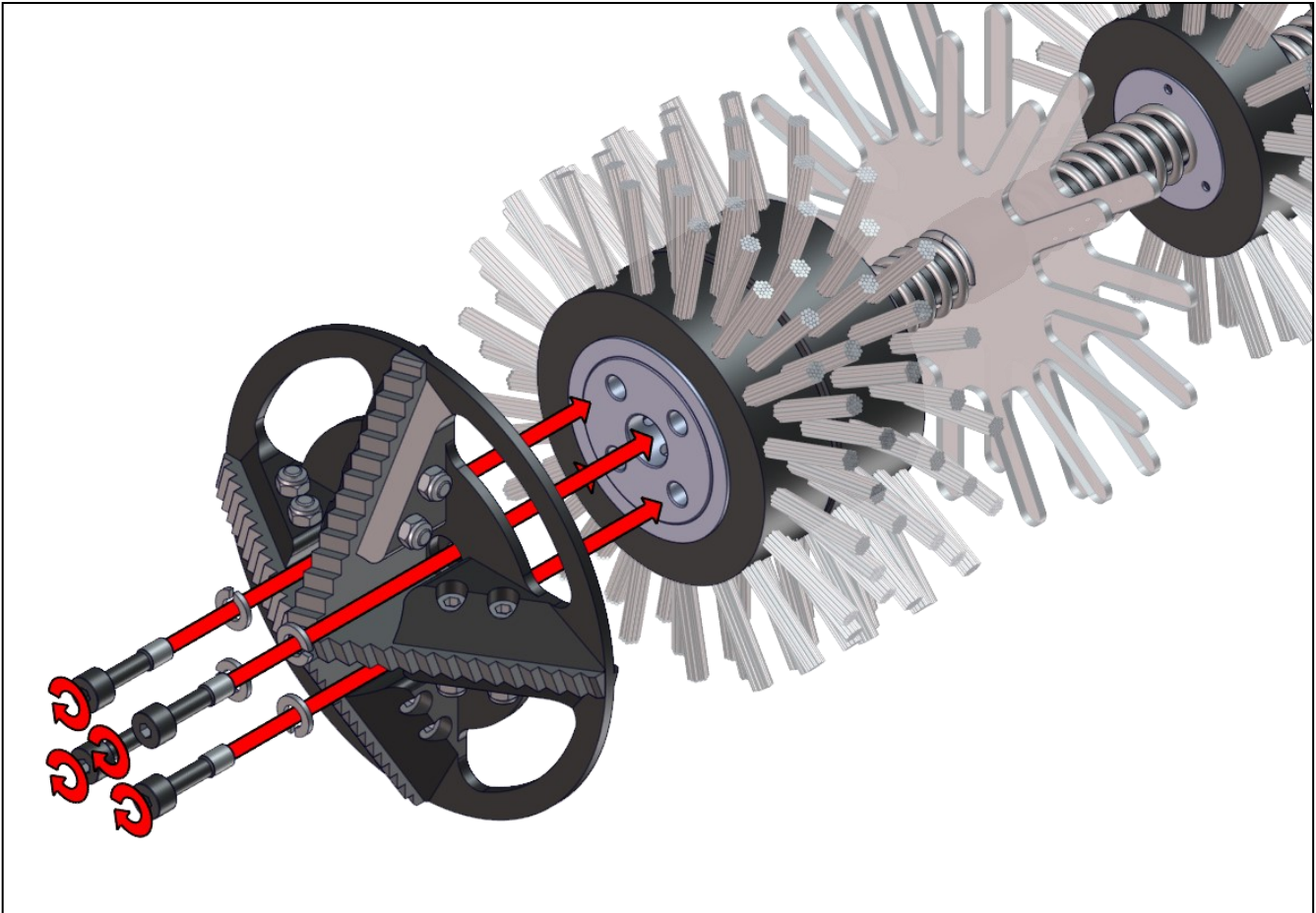
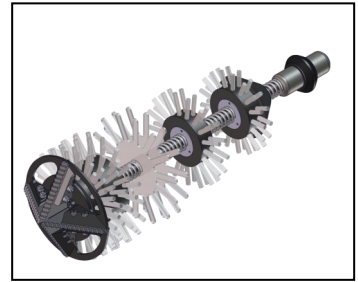

Using the Twister+ products



Before starting work

Select the correct size tooling and drill head for your job. Ensure water is flowing in the pipe or the vacuum extraction is ready (dry cleaning). Ventilate the working area properly. Ensure that all metallic drain pipes are grounded/earthed. The Twister+ causes high friction and there is risk of electric shocks. Verify the location to position the Twister+ with a CCTV camera. Place the Twister+ inside the pipe ensuring that legs fit completely inside the drain before turning the power on.

During use

Switch the power on. Initially start the Twister+ at a lower speed and then slowly increase the speed. Adjust the speed while working. Tightly hold the shaft. Move the tool in a back and forth movement within the pipe. Always use a CCTV camera to check how you are progressing.

Do not force the tool through the pipe—let the tool do the work. If too much force or excessive high speed is used the tool might get stuck resulting in damaging or breaking the tool, shaft or the pipe. Use either water or vacuum to remove the debris. Use a lower speed when working in fragile or damaged sections of the pipe.



PLEASE NOTE: Take all the shaft out from the reel when possible. It prevents the outer casing from melting and provides more power to the tool head. Where water cooling is not being used (air/vacuum situations), you need to take breaks every 10–15 min as the tool head gets very hot during use. Always wear heat resistant gloves after the machine has been switched off and the power supply isolated. The tools can then be cooled down using water or left to cool in the open air. Always observe the temperature of the outer casing and let the **Maxi Miller Power+** cool down after every 30 min periods of constant work.

Please read safety information on page 3 before assembly and use.

Using Twister products



After use

WARNING: Turn the power off and isolate the supply before you remove the tool from the pipe. There is a risk of serious injury or death! The tool can be very hot. Carefully take the tool out from the pipe

Check out the condition of the tooling and shaft. Replace worn-out parts. If shaft looks damaged, remove decrepit part with an angle grinder and shorten outer casing accordingly.

Where required the Twister+ drill head or drill blades can be sharpened with a grinder. Do not remove more material than you must because the outer hard layer is only 2-3 mm thick.

RECOMMENDATIONS

Take all the shaft out from the reel when possible. It prevents the outer casing from melting and provides more power to the tool head.

Do not power up the Twister+ products outside of the pipe! The tooling needs to fit completely inside the pipe before use.

Select rotation speed between 650—1200 rpm. Optimal rotation speed is normally between 1000 rpm and 1200 rpm.

Use water cooling when possible.

Always take a break after every 15 mins to prevent outer casing from melting. Regularly inspect the condition of the outer casing.

Please read safety information on page 3 before assembly and use.

MAINTENANCE

CARING FOR THE FLEXIBLE SHAFT

Prior to shipping the flexible shaft is pre-treated with **paraffin oil** and the outer casing replaced. Always inspect the condition and when required apply paraffin oil between the flexible shaft and its outer casing. If necessary remove the shaft from its casing to treat. When the casing has been re-placed, manually rotate the shaft for even coverage.



TWISTER+ DRILL HEAD/SMART CRUSHER

If the Drill Head/Smart Crusher replacable blades are worn or are cracked, they should be changed. For the best outcome, it is recommended that all the drill head blades are changed at the same time.

FASTENER SCREWS

Replace the fastener screws immediately if you are unable to fully tighten them due to worn out hex socket heads. Otherwise, a panel could detach from the hub during the cutting operation and fall into the pipe.



SPARE PARTS

Twister+ product family

1300215130	Front Drill Head DN150 130mm
1300215175	Front Drill Head DN200 175mm
1300215200	Front Drill Head DN225 200mm
900000694	FDH Blade DN200 4pcs/package
900000716	FDH Blade DN225 4pcs/package

Please contact your reseller for more information.

SPARE PARTS — Smart Crusher Drill Head

1300218150	Smart Crusher Front Drill Head DN150 w/4 blades & 4 screws
1300218200	Smart Crusher Front Drill Head DN200 w/4 blades & 4 screws
1300218225	Smart Crusher Front Drill Head DN225 w/4 blades & 4 screws
900000663	Blade DN150 4pcs/package
900000709	Blade DN200 4pcs/package
900000710	Blade DN225 4pcs/package

SPARE PARTS — Other

1350000102	Picote Allen Bolt M8x30 "light"
1313002185	Shaft Connector 18 mm
9575034-1	Strain Relief Maxi Power+
1312021180020	Maxi Power+ spare shaft 20.5m
1312021180011	Maxi Power+ extension shaft 11m
93212520180SB	Sleeve for 18mm outer casing

MILLER

3570032016	MAXI MILLER POWER PLUS 18/18 400V
------------	-----------------------------------

TRAINING

For information about product training and support contact Picote Solutions or your authorized Picote reseller.

PRACTICAL TIPS & SAFETY ADVICE

Here are some useful tips on how to get the most out of your Picote system. Always use the recommended tools for maintenance to avoid personal injury.



CUTTING THE FLEXIBLE SHAFT



Always inspect the flexible shaft before each use. If there are potential weak points or the shaft is damaged, cut off the damaged length using a band saw.



SHAFT ROUNDER



The shaft rounder smooths the end of the flexible shaft, preventing the user from being cut by the otherwise sharp metal edge.



ATTACHING A SHAFT SOCKET



Feed the shaft through the socket to the end and **securely fasten**. To protect the shaft the outer casing should reach all the way to the base of the shaft socket.

ADDING A VISUAL MARKER FOR SAFETY



For your safety attach a visual marker (tape) to the outer casing of the flexible shaft. Place it around half a meter from the end point of the shaft. The marker will indicate the tool's location and prevent possible injuries, from the rotating parts, when the Smart Cutter is removed from the drain.



CREATING LEADERS

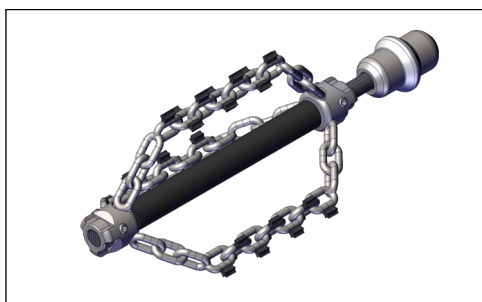

You can extend the life of the flexible shaft and increase productivity on site by making individual leaders for the most commonly used tools. This way you easily and quickly switch between tooling.

WARRANTY POLICY AND PROCEDURE

Limited Warranty:

Picote warrants to the original End User that the Product purchased by such End User will operate in accordance with and substantially conform to their published specifications when shipped or otherwise delivered to the End User and for a period of one (1) year, except electric motors for which the warranty period shall be six (6) months, provided, however, that Picote does not warrant any claim or damage under this

Warranty if such claim or damage results from:

1. Consumable parts or normal wear and tear resulting from use of the Products,
2. Product overload or overheated motor,
3. Regular periodic maintenance of Products,
4. Misuse, neglect, or improper installation or maintenance of the Products, or use of Products not for their intended purpose,
5. Products that have been altered, modified, repaired, opened or tampered with by anyone other than Picote or an authorized Picote Service Centre, or unsuitable or unauthorized spare parts, accessories or third party products when using the Products or;
6. the use of the Products not in compliance with their respective Documentation, user manuals, safety and maintenance instructions, and any usage restrictions contained therein, or
7. accident, fire, power failure, power surge, or other hazard.

Otherwise, the Products are sold AS IS. End User is responsible for using the Products within their specifications and instructions as contained in the Documentation.

EXCEPT AS SPECIFIED IN THIS WARRANTY, ALL EXPRESS OR IMPLIED CONDITIONS, REPRESENTATIONS, AND WARRANTIES INCLUDING, WITHOUT LIMITATION, ANY IMPLIED WARRANTY OR CONDITION OF MERCHANTABILITY, FITNESS FOR A PARTICULAR PURPOSE, NONINFRINGEMENT, SATISFACTORY QUALITY OR ARISING FROM A COURSE OF DEALING, LAW, USAGE, OR TRADE PRACTICE, ARE HEREBY EXCLUDED TO THE EXTENT ALLOWED BY APPLICABLE LAW. TO THE EXTENT AN IMPLIED WARRANTY CANNOT BE EXCLUDED, SUCH WARRANTY IS LIMITED IN DURATION TO THE WARRANTY PERIOD. BECAUSE SOME STATES OR JURISDICTIONS DO NOT ALLOW LIMITATIONS ON HOW LONG AN IMPLIED WARRANTY LASTS, THE ABOVE LIMITATION MAY NOT APPLY. This disclaimer and exclusion shall apply even if the express warranty set forth above fails of its essential purpose.

Please Contact:

Your Reseller or Picote

www.picotegroup.com



International Offices

Finland. United Kingdom. USA.

Technical Support

support@picotesolutions.com

Claims

claims@picotesolutions.com

Production & R&D

Pienteollisuustie 24

06450 Porvoo, Finland

support@picotesolutions.com

Authorized Resellers:

www.picotegroup.com/resellers